

EFCO Technology

Application Note

Document Name	AN11_Eagle Eyes for Remote Power Button Setting
Applicable Products	All Eagle Eyes series
Application Note Subject	Remote Power Button Setting
Usage Designation	<input type="checkbox"/> Internal <input checked="" type="checkbox"/> External

Preface

Revision History

Revision	Date	Author	Description
1.0	2021/03/16	J Yen	Preliminary release

Copyright

Copyright © 2021 EFCO Technology. All rights are reserved. EFCO reserves the right to make improvements to the products described in this manual at any time without notice.

No part of this manual may be reproduced, copied, translated or transmitted in any form or by any means without the prior written permission of EFCO. Information provided in this manual is intended to be accurate and reliable. However, EFCO assumes no responsibility for its use, nor for any infringements of the rights of third parties, which may result from its use.

The material in this document is for product information only and is subject to change without notice. While reasonable efforts have been made in the preparation of this document to assure its accuracy, EFCO assumes no liabilities resulting from errors or omissions in this document, or from the use of the information contained herein.

EFCO reserves the right to make changes in the product design without notice.

Acknowledgements

All brand names and/or trademarks are the properties and registered brands of their respective owners.

For more information about this and other EFCO products, please visit our website at: www.efcotec.com

Warnings, Cautions and Notes

Warning! Warnings indicate conditions, which if not observed, can cause personal injury!



Caution! Cautions are included to help you avoid damaging hardware or losing data.



Note! Notes provide optional additional information.



Title

How to connect AIH/AIM series remote power button and power LED?

Answer

1. General Introduction

"Remote/IGN" connector supports remote power control and power LED. When plugging DC input power, push remote power switch to turn the power on, and the system power LED is on. When system in power on mode, push remote power switch again to turn off the system, and the power LED will be off.

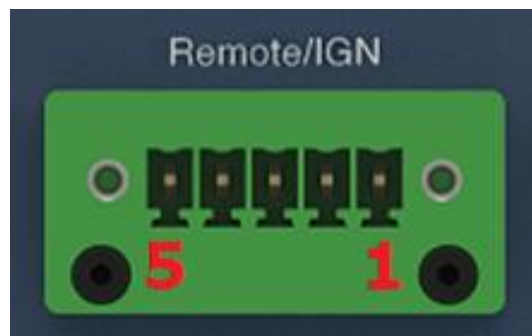

3.81mm 1x5 Terminal Block

2. Pin Define

Pin No	Description
1	Ignition+
2	Ignition-
3	Power Button_N
4	GND
5	Power LED+

Note!



- a. Ignition + Pin Voltage/Currents: Follow AC adapter input voltage/100mA
- b. Power LED + Pin Voltage/Current: +3V/10mA
- c. Power button needs using push switch type

3. Set up Remote Power Button with 3V LED Connection

Connect "Remote Power switch" at Pin 3 & Pin 4, and "Power LED" at Pin 4 & Pin 5 of the Remote/IGN connector.

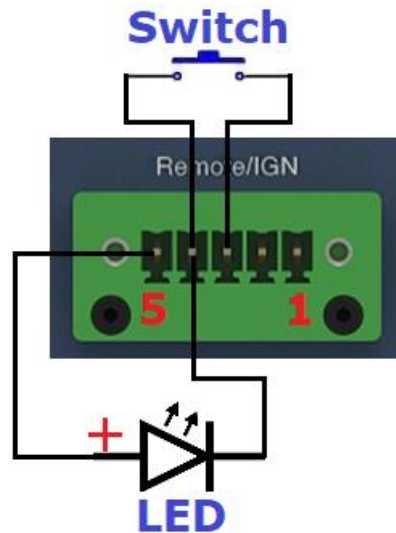

4. Set up Remote Power Button with 12V/24V LED Connection

The setup is the same as Step 3. The reason that the LED's brightness is not enough, is Pin 5 only provides 3V/10mA power. The solution is to use "ING+" pin to drive 12V/24V LED with redefine of Pin 5 at Remote/IGN connector.

AIM Series--

a> Connector location

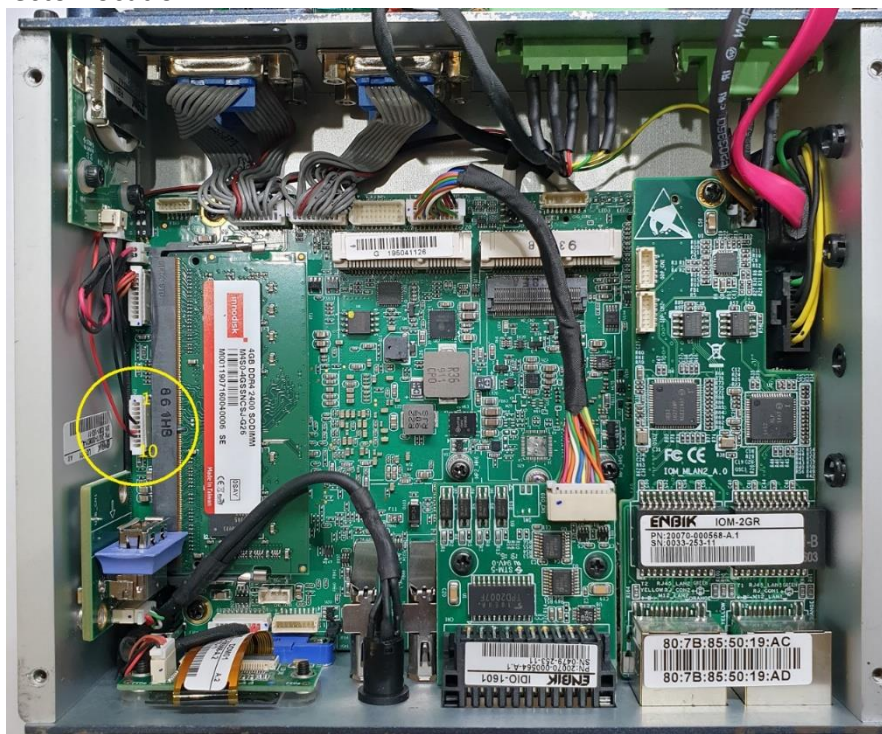

b> Change cable Pin 5 to Pin 6.

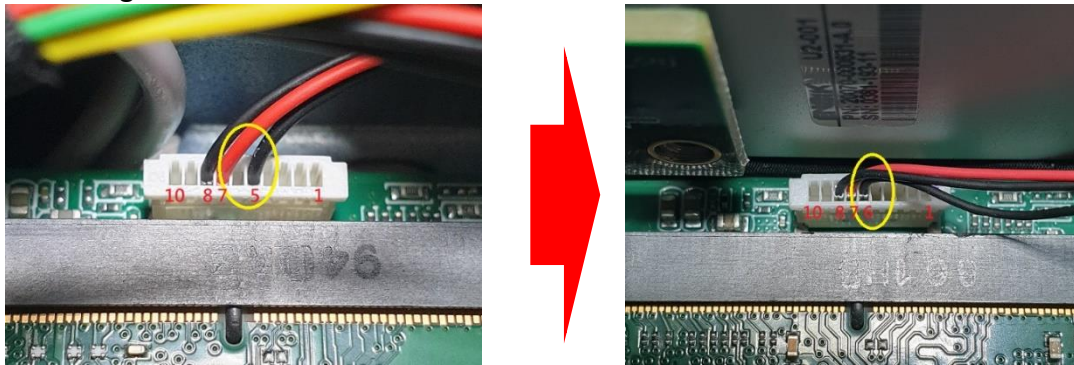

AIH Series--

c> Connector location

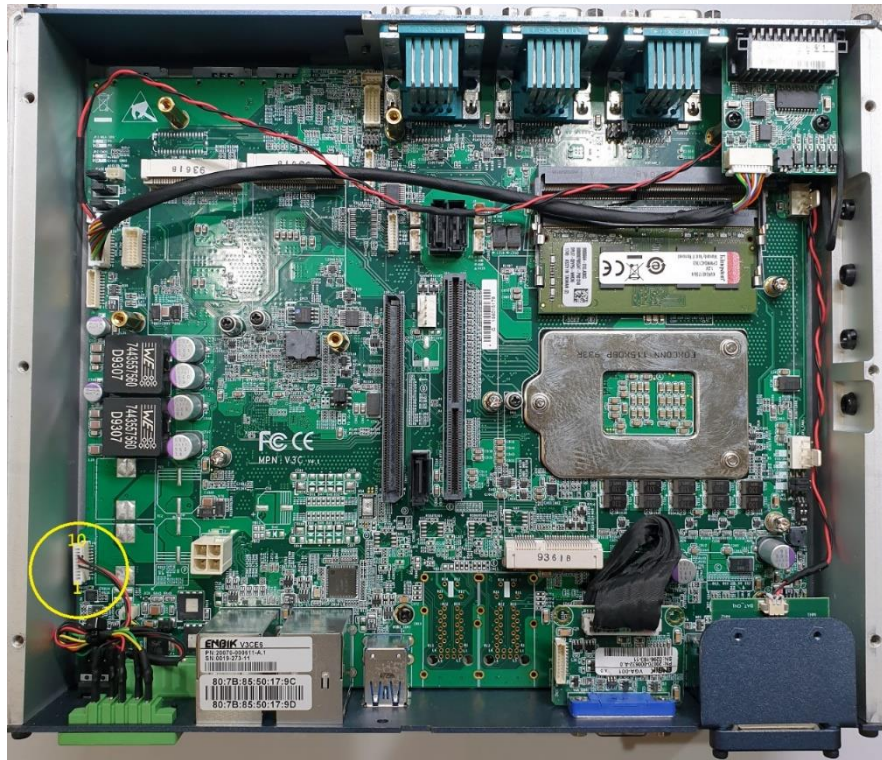

d> Change cable Pin 5 to Pin 6.

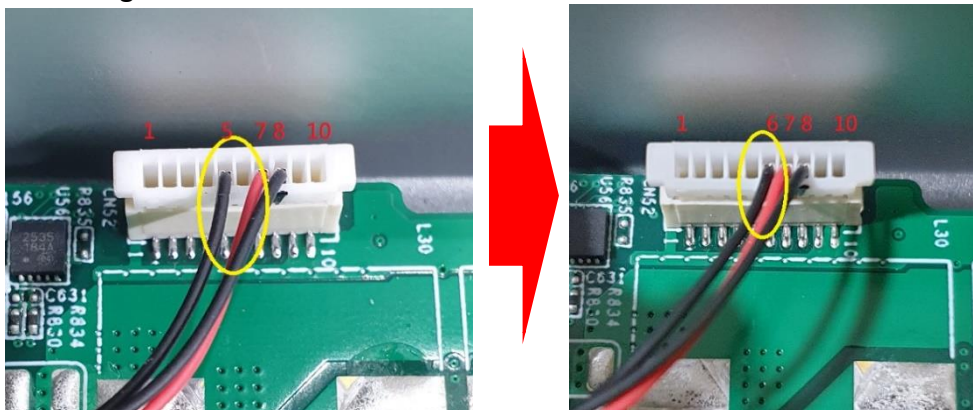

5. Connect Remote Power Switch at Pin 3 & Pin 4, and "Power LED" at Pin 1 & Pin 5 of the Remote/IGN Connector

** Please add a current-limiting resistor between Remote/IGN connector at Pin 1 and LED+ Pin 1 to protect power switch LED**

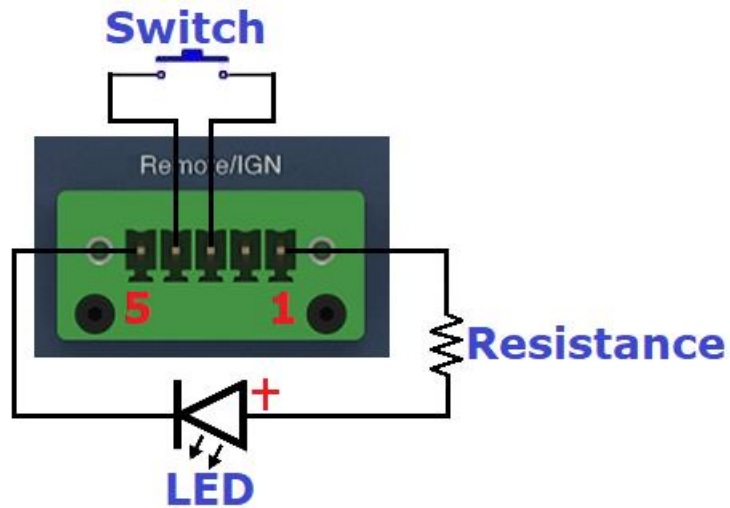

Example:

Remote power button LED: **24V**

Current-limiting resistor: **1.2K Ω**

